



Introduction to DSLRs

PMUG SIG, March, 2021



Contents

- What is a DSLR?
- Types & brands
- Sensors - why does it matter?
- Basic principals
- Basic operating controls
- Lenses

Philosophy

- Geared to beginners or occasional users
- Provide basic ground works for understanding how your camera works and how to best use your new DSLR
- Contrasts DSLR vs iPhone
- My background and cameras
- Your background and camera?

Bought first SLR in 1968. Owned 3 film SLRs and processed my own film in 1973. In job, processed satellite digital images with professional software from 1980 on. First personal digital camera in 1995 (640x480 chip) . First DSLR Canon EOS 500D Rebel T1 in 2009. Then a Rebel T3, then an EOS 50D, then an EOS 70D, and now an EOS R5. My professional imaging background taught me to only adjust the radiometric (color) values, and NOT the subjects or any other spatial object in the photo. If I can not take the picture I want, why spend the time to edit it to make it the picture I want???



DSLR



- Camera that lets you see what the lens sees
- Point & shoot uses separate view finder
- SLRs developed early 1950's
- DSLR developed early '90s
- Replaced Film SLRs



I ALWAYS know that the lens cap is off with an slr!!!

Demise of Film

- Film made from Silver Halide and silver price went up
- Processing Chemicals had more restrictions put on their disposal
- Computers able to handle images of increasing size and complexity and processing

Camera Categories

- Compact cameras (point & shoot) - simple, inexpensive
- Bridge super-zoom DSLRs - Below SLR price



Point & shoot - fixed lenses, separate view finder

Bridge dslrs are smaller cheaper with motorized inexpensive zoom lens, often a very powerful (1200mm) lens, but without optics as good as DSLR separate lens

Camera Categories

- DSLR Cropped sensor
- DSLR full frame
- Mirrorless DSLR
- Medium format



Cropped sensors are “smaller” than full frame. Film SLR people are fussy about this.
Full frame is same sensor size as “35mm” film size - terminology is holdover from the film cameras

DSLR Schematic

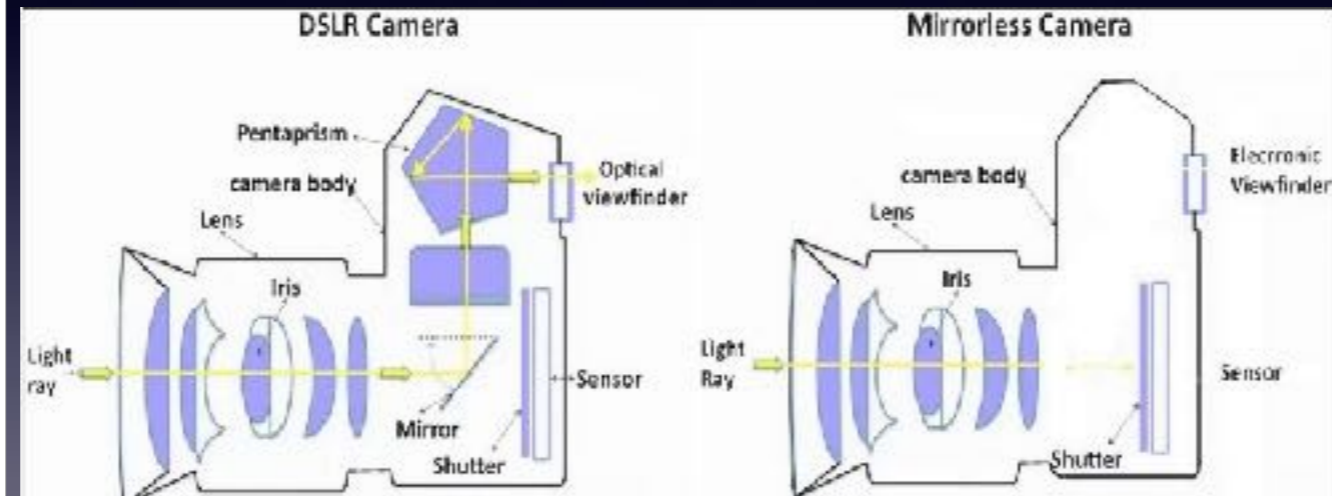

Mirror vs Mirrorless

- SLRs popular since 1950's
- DSLR's have 40 years of advancements
- Advantages of Mirrored DSLRs
 - Battery life
 - Optical view finder
 - Some photographers prefer a heavy camera

2017, total mirrorless shipments were up by nearly 30 percent, while DSLR shipments dropped by 10 percent. The Americas, long a bastion of the DSLR, saw an even more dramatic shift, with mirrorless shipments up 46 percent (DSLRs dropped a tad less than the international total, by 7 percent).

Mirror vs Mirrorless

- Mirrorless camera created by Epson in 2004
- Not a DSLR, only a 4/3 chip and no interchangeable lens
- Sony added Full Frame & interchangeable lenses in 2013 with A7
- ALL new mirrorless DSLRs have wide variety of lenses

Mirror vs Mirrorless

- Advantages of Mirrorless
 - More shock resistant
 - Mirrorless smaller & lighter weight
 - Quieter with better Autofocus speed
 - Live histogram and better stabilization

2017, total mirrorless shipments were up by nearly 30 percent, while DSLR shipments dropped by 10 percent. The Americas, long a bastion of the DSLR, saw an even more dramatic shift, with mirrorless shipments up 46 percent (DSLRs dropped a tad less than the international total, by 7 percent).

Comparison of DSLR vs Mirrorless

	DSLR	Mirrorless
Size & Weight		✓
Autofocus Speed	✓	✓
Previewing Images	✓	✓
Image Stabilization		✓
Image Quality	✓	✓
Video Quality		✓
Shooting Speed		✓
Battery Life	✓	
Lenses & Accessories	✓	✓
Durability	✓	✓
Total	6	8

Light Capture

- First permanent photo captured in 1825!
- First Daguerreotype in 1839
- First Photographic film in 1885
- First Digital Sensors (CCD & CMOS) created in 1969
- CCD commercial based, CMOS consumer based

Film SLR

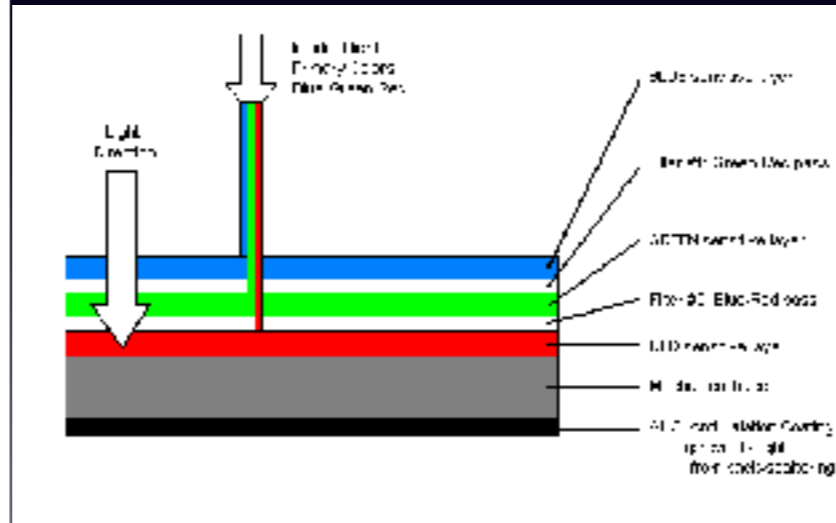

- Film contained 3 layers: R, G, B
- Light filters between 1st & 2nd Layer
- Processing exposed the silver halide of each layer

DSLR

- Only one sensor for all three colors (Foveon exception)
- “Bayer Filter” creates color image using one sensor

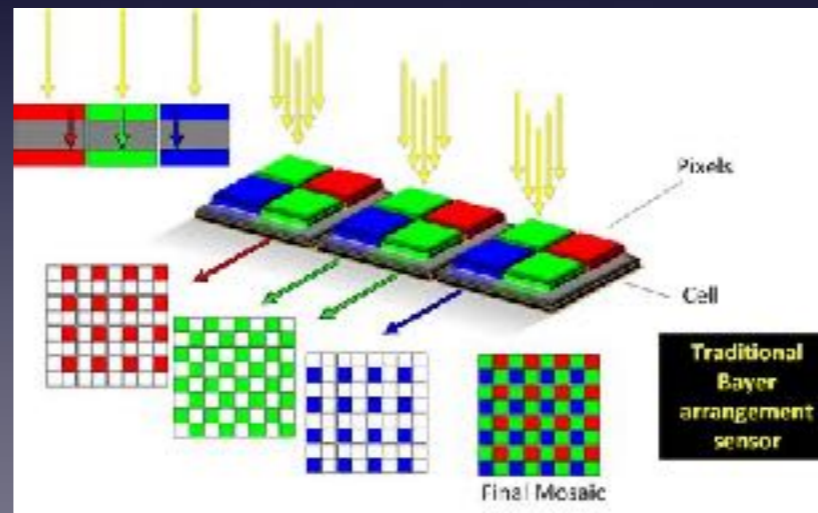

Digital Sensor Exposure

- Only 50% of Green light, 25% of Red and Blue light captured
- Requires interpolation algorithm to “fill in” missing pixels not measured

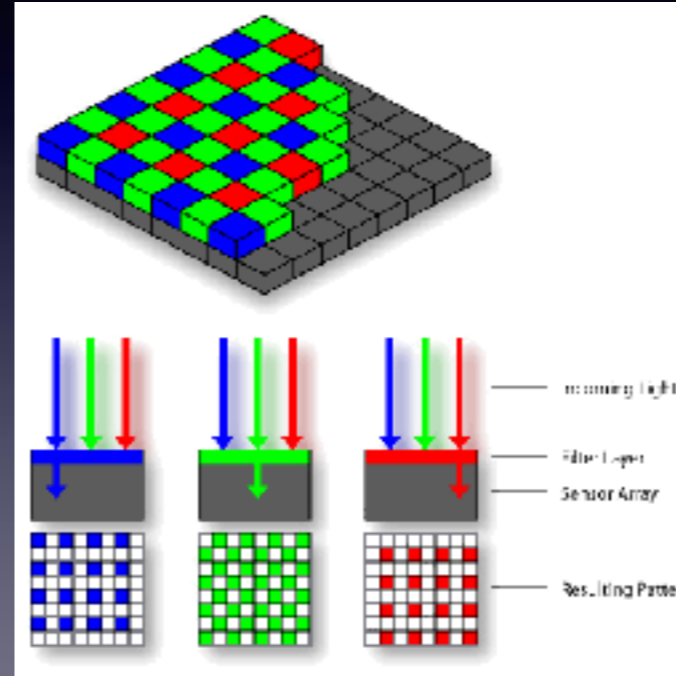

Bayer Filter Interpolation

bilinear interpolation is depicted.



- Means red and blue light are more interpolated (scientifically guessed at) than green

Sensor size

- Sensor Size DOES matter - its a light gathering issue. Sensor size & # of pixels related to light...
- The larger the individual pixel the more light that can be collected
- The bit depth of each pixel also relates to light captured (8 bits-256 values vs 12 bit-4096)
- Light is converted to electrons which are measured by the Bayer filter color

Sensor size

Sensor Type	Width & Height (mm)	Diagonal (mm)	Sensor Area (sq. mm.)	Crop Factor
Medium Format	53.7×40.2	67.08	2159	0.65
35mm Full-Frame	35.8×23.9 to 36×24	43.1–43.3	856–864	1.0
APS-H	27.9×18.6	33.5	519	1.29
APS-C (Nikon, Pentax, Sony, Fujifilm, and Sigma)	23.6×15.6	28.2–28.4	368–370	1.52–1.54
APS-C (Canon)	22.3×14.9	26.82	332	1.61
Four Thirds / Micro Four Thirds	17.3×13	21.6	225	2.00
1" Type	13.2×8.8	15.86	116	2.72

- iPhone 11 & 12 sensors are ~ .5" in size, 8 bit deep:
Reason why iPhone is still a 12MP sensor

The EOS R5 has a 4x capability of light gathering based on size alone. Each pixel is 14bit raw depth, which is significant improvement (256 values vs 16384 values!!)

Sensor size

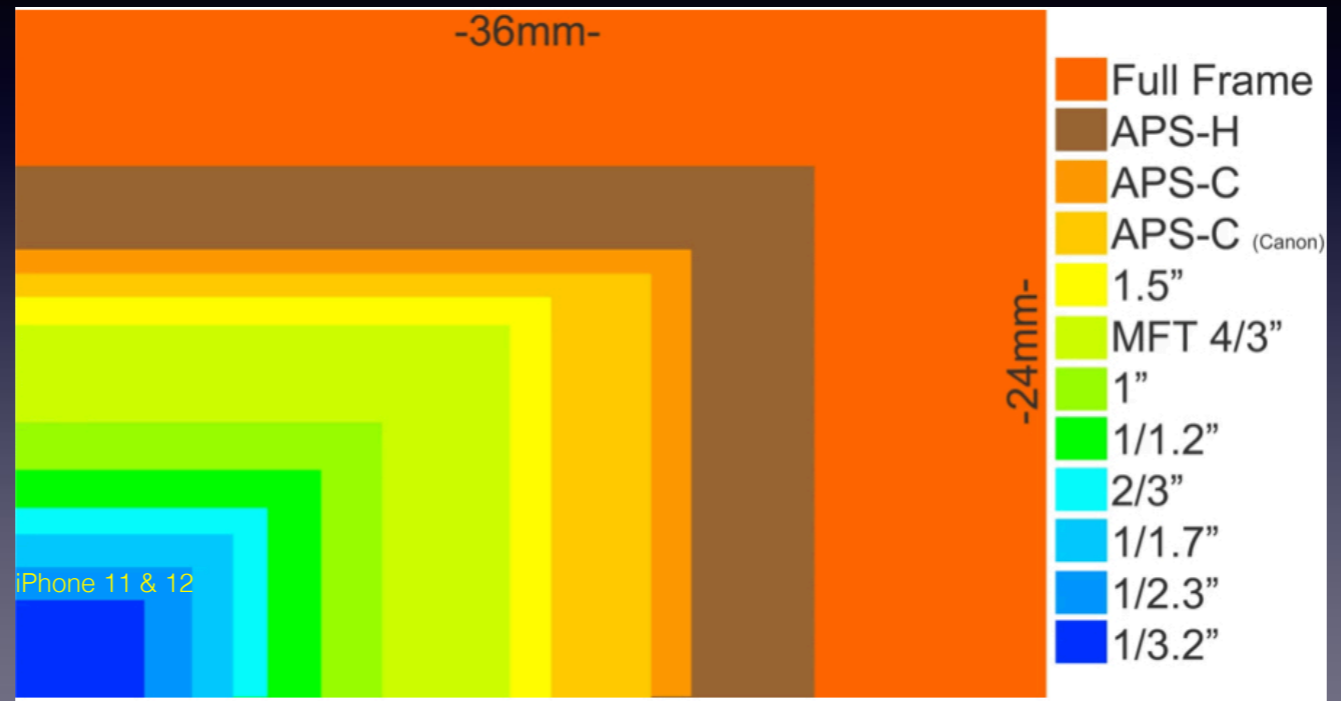

Light Capture

- Three basic controls in camera to manipulate the amount of light captured
- ISO
- Shutter Speed
- Aperture

Exposure Triangle

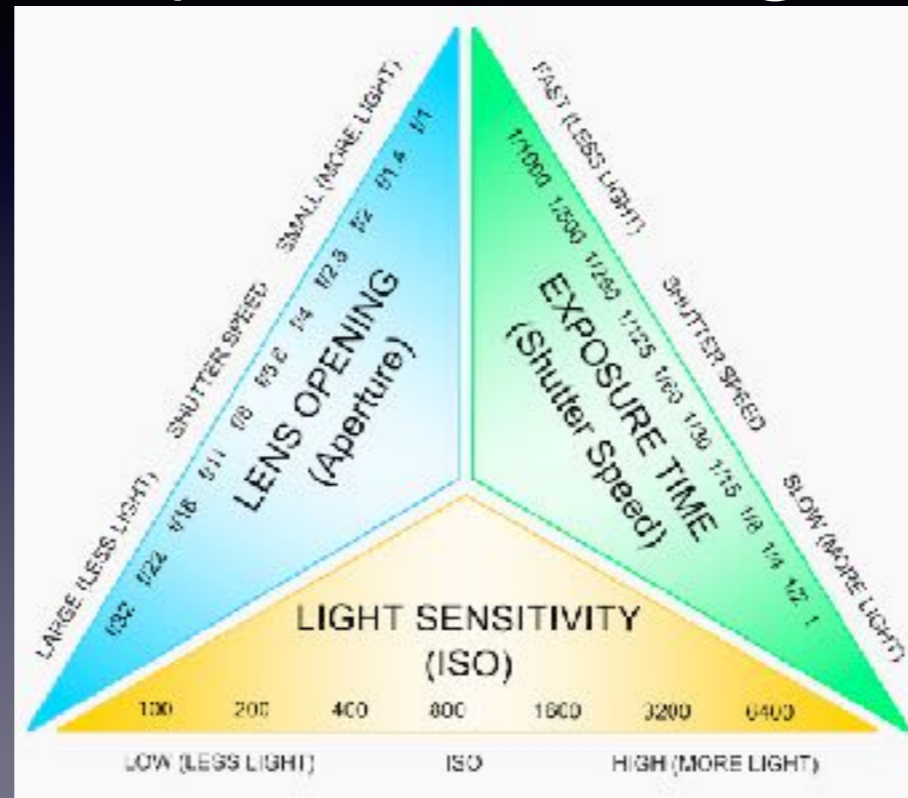

ISO

- In film, it represented the size of the individual silver halide crystals. The larger the crystal, the less light needed, but the less the resolution
- In DSLR, it is indicative of how sensitive the sensor is to light or the brightness of the image
- Double the ISO, double the brightness
- Increasing the ISO increases digital noise!!

ISO

Low ISO

High ISO

- The higher the ISO in a DSLR the more the electronic noise

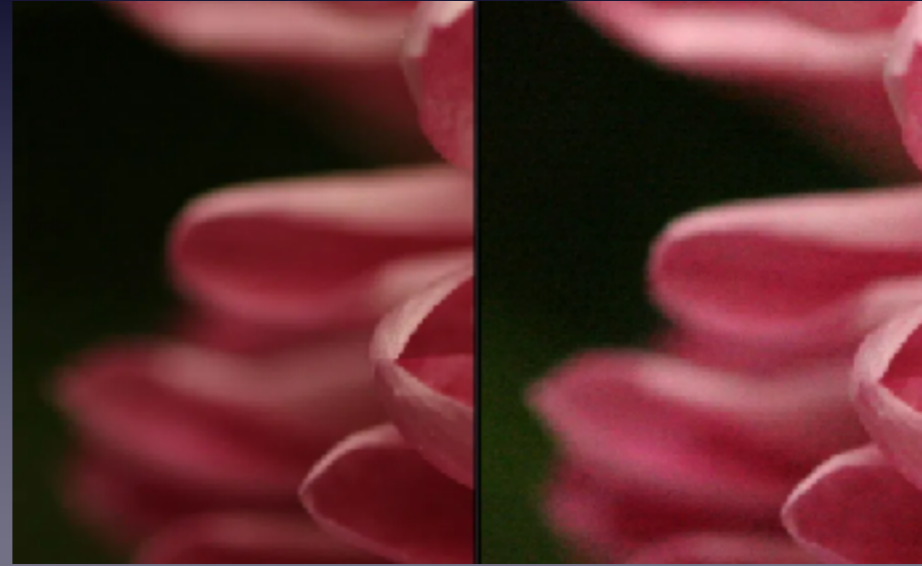

ISO

- General Rules for setting ISO
 - Use 100-200 when in sunny conditions
 - Overcast skies require 400-800
 - Low light, dusk, Dawn require 800-1600
 - Night time try 2,000-10,000

Shutter Mechanism

How the shutter works

Focal plane

SLRs use what is known as 'vertical run focal plane' shutters – as the blinds run up and down, and are found just in front of the sensor.

Twin blinds

The shutter mechanism is made up of two gossamer-thin blinds. One drops open to start the exposure, the second follows to close the opening.

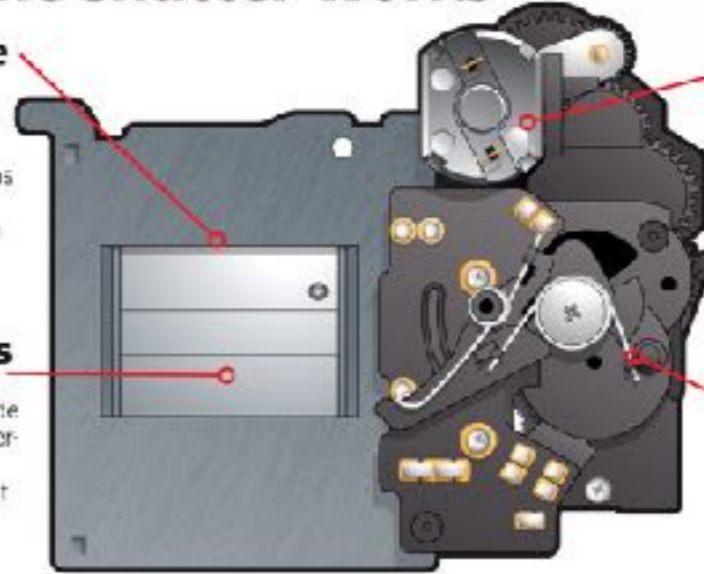

Motor

The shutter mechanism has its own motor, for firing and cocking the blinds. A separate motor is used for the mirror, which must be raised just before the shutter is fired.

Longevity

The shutter durability varies considerably from model to model.

www.digitalcameraworld.com



Shutter Speed

- The speed which opens and closes the shutter which lets in light
- Measured in seconds and the number is 1/speed (so shutter speed of 800 is really 1/800 sec)
- Faster shutter speeds “freeze” the motion
- Slower shutter speeds “blur” the motion

Shutter Speed

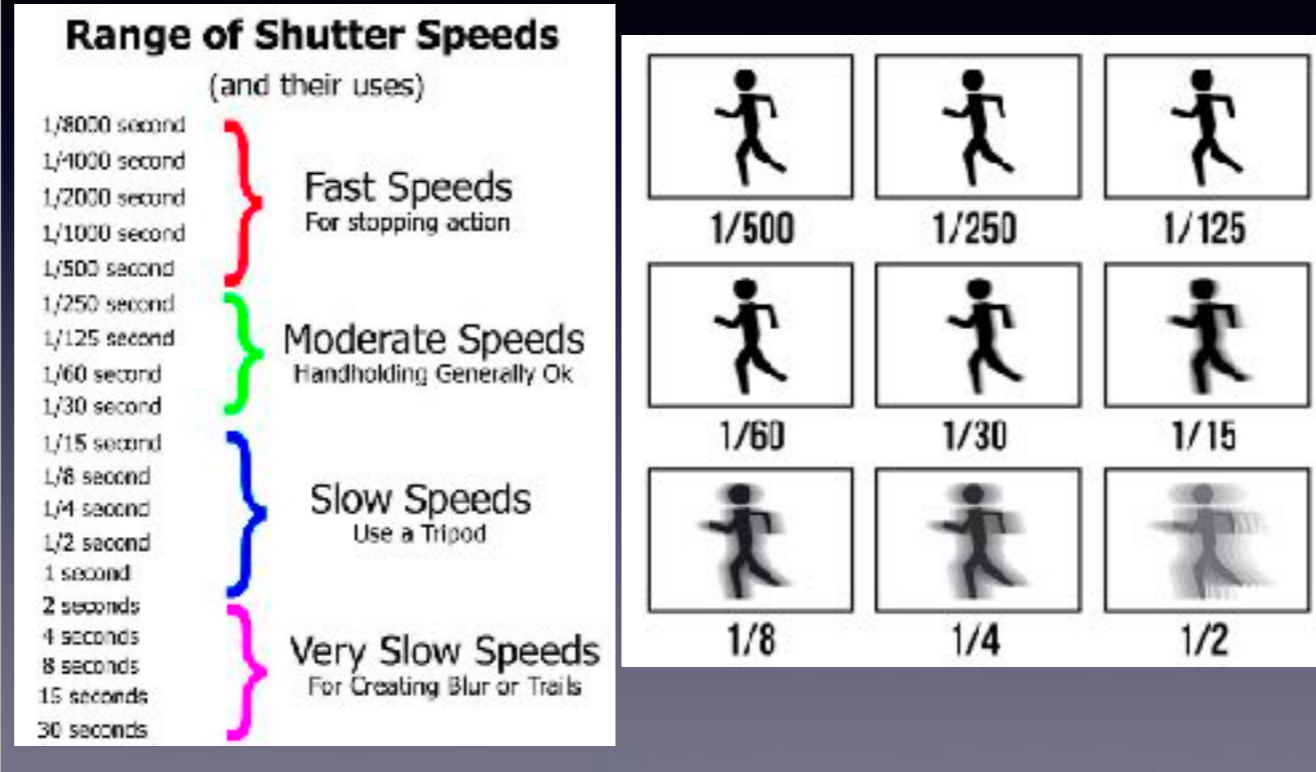

Aperture Mechanism

- The size of the opening that lets light in



Aperture

- f/1.4, f/2, f2.8, f/4, f/5.6, f/8, f/11, f/22, f/32
- Open the aperture by one value doubles the light entering
- Equal to 1EV (exposure value)
- Telephoto lenses have larger f/ stops
- f/9 - f/11 generally provide sharpest image

Depth of Field

- Aperture also controls the depth of field - focus



Depth of field: the amount of the image that is in focus. A band of data across the width of the image. Closer or further objects out of focus. The closer the object that is focused on, the smaller the depth of field. The smaller the Aperture, the shallower (smaller) the depth of field.

iPhone Controls

- Choose ISO 25-2500
- Choose Shutter 1/1 to /12000
- Fixed Aperture based on lens (Ultra Wide f/2.4, Wide f/1.6, Telephoto f/2.0)

iPhone 12 Pro Additions

- Adds a LiDAR scanner to do faster autofocus in low light conditions
- LiDAR allows night mode portraits
- Apple ProRAW output (but several Apps allow same capability)
- Dual optical image stabilization

Time to Use It

- Pick up your Cameras
- Find Exposure button
- Find menu button
- Find control wheels

Getting Around Nikon











Getting Around Nikon



Getting Around Canon



Canon EOS R5 Controls

(1)	Eyecup
(2)	Viewfinder eyepiece
(3)	<MENU> Menu button
(4)	Speaker
(5)	Terminal cover
(6)	LCD panel
(7)	<LOCK> Multi-function lock button
(8)	<  > Quick control dial 2
(9)	< AF-ON > AF start button
(10)	< * > Multi-controller (can also be pressed straight in)
(11)	< Q > Magnify/Reduce button
(12)	<  > Quick Control button
(13)	< INFO > Info button
(14)	<  > Set button
(15)	Access lamp
(16)	<  > Erase button
(17)	<  > Playback button
(18)	Voice memo microphone
(19)	Viewfinder sensor
(20)	< RATE > Rating/Voice memo button
(21)	< MIC > External microphone IN terminal
(22)	<  > Digital terminal
(23)	< HDMI OUT > HDMI micro OUT terminal
(24)	<  > Headphone terminal
(25)	<  > PC terminal

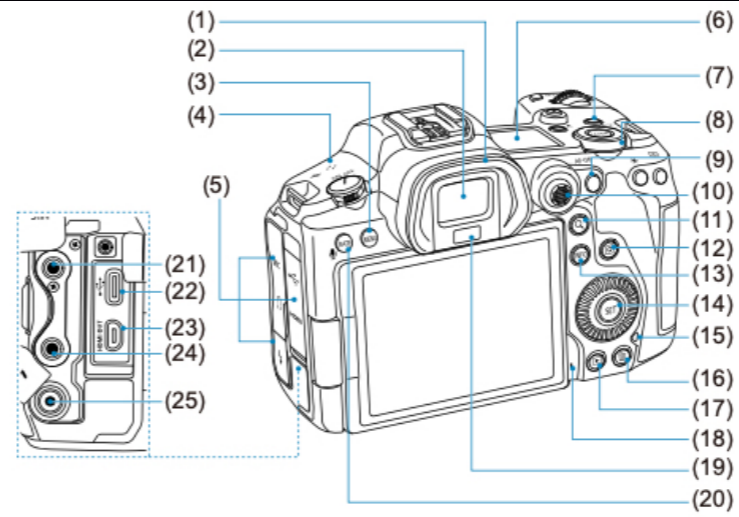

Getting Around Canon



Canon EOS R5 Controls

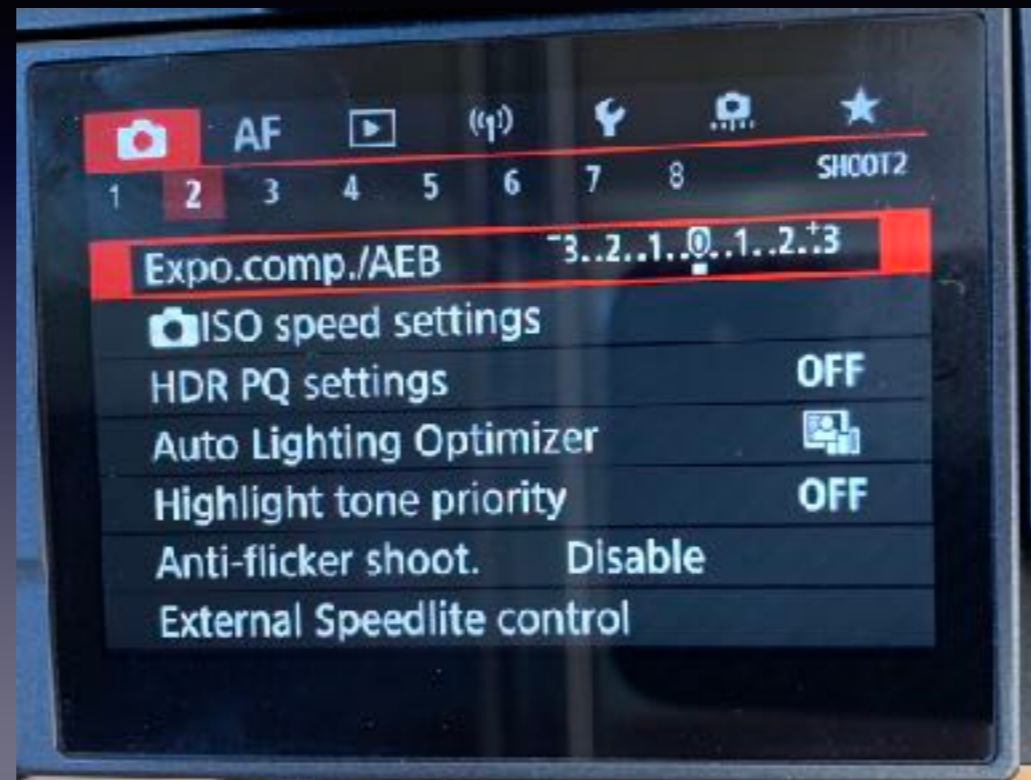

Basic Controls

- Basic Modes - Manual, shutter or aperture priority, automatic
- Lots of programmed modes - dependent on model
- Three basic controls to measure light:
 - ISO
 - Shutter
 - Aperture
- Light measuring method: use a point, center average, or average
- Focusing - manual or auto, focus point

Advanced Controls

- Image Stabilization
- Full time focus
- Exposure compensation
- Auto Focus
- GPS, BlueTooth, WiFi
- Software features: HDR, Panorama stitching, stacking, etc

Full Auto Mode



- Settings available for fully automatic (Camera does light measurement, and sets all 3 values)
- Or semi-auto (you set ISO, camera sets shutter & aperture)
- Little control over depth of field or blur of subject

Shutter Priority

- Allows you to set the shutter speed
- For action/movement/wildlife shots need fast shutter speed
- Camera then selects aperture setting for optimum light capture
- Camera setting may also allow ISO change if Aperture not sufficient



Shutter Priority

- Can also set to slow or very slow speeds for creating blur
- Use tripod to prevent shake
- Useful for night shots



Shutter Priority



- Used with Neutral Density filter to darken the scene with tripod and very slow speed

Aperture Priority

- Most commonly used mode
- Allows you to set the aperture opening
- Allows you to control the depth of field
- Camera then sets shutter speed optimum light capture
- Camera setting may also allow ISO change if shutter speed not sufficient



Aperture Priority

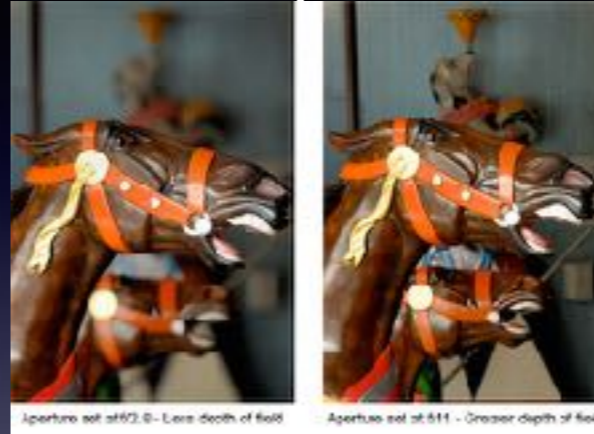

- Use for Landscapes
- Use for still shots - no movement
- Measure in “f/stops” - f/1.4 is wide open, f/22 is nearly closed
- f/11: Ideal aperture for landscapes

Light Measurement

- Spot, partial, center-weighted, evaluative
- On iPhone, tap the picture for point, otherwise an average (evaluative)
- On DSLR, move point or select average type
- Use Exposure Compensation to change



Full Manual

- Used in the past by professionals & expert users
- You set the ISO, Aperture & Shutter speed
- Based on your experience or results of taking an image
- Necessary for night shots



Advanced Settings

- Stacking



- Exposure Compensation & Histogram
- HDR - High Dynamic Range - 3 exposure settings (-2, 0, +2), 3 exposures (AEB), merging, processing (in camera)
- Panoramic - Auto Stitching &

HDR Example

-2EV

0 EV

+2EV

HDR



Panorama



Lenses

- This is the optical (glass) part
- Controls the magnification of image

DSLR

- Multiple lenses to correct the image

iPhone

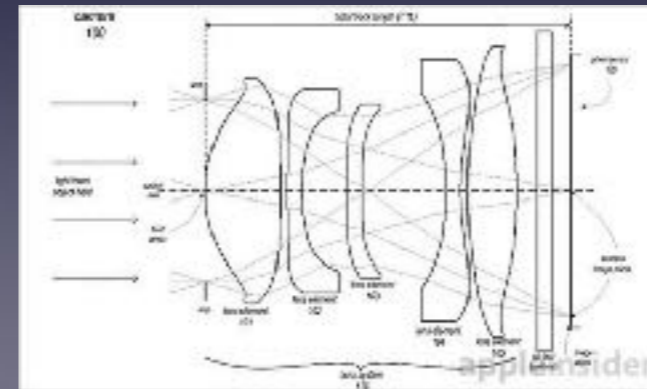
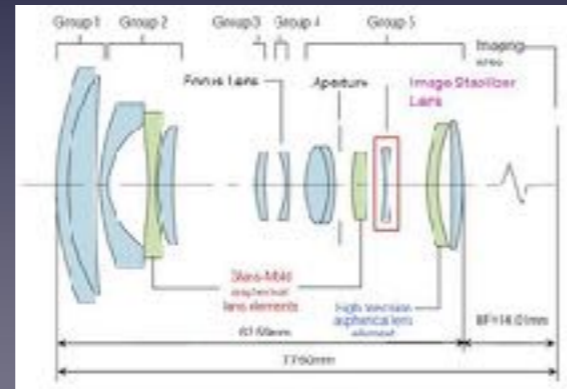

iPHONE LENSES

- Ultra Wide is a 13mm lens
- Wide is a 26mm lens
- Telephoto is a 52mm lens
- Higher the mm size, the further apart the elements need to be.
- That is why the 52mm ONLY on the Pro - cost

iPHONE LENSES

- Wide Only: iPhone SE, XR, 8, 7
- Ultra Wide & Wide: iPhone 12, 12 mini, 11, SE,
- Wide & Telephoto: iPhone XS, X, 8 Plus, 7 Plus
- UltraWide, Wide & Telephoto: iPhone 12 Pro & 12 Pro Max, 11 Pro & 11 Pro Max,

DSLR Lenses



- Macro - 1x power at VERY CLOSE range
- Fish eye - 180 degree of view
- Ultra-wide - <20mm (full frame)
- Wide - 20mm to 35mm
- Normal - 35mm to ~ 70mm

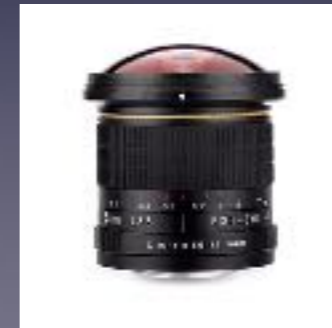

Macros have very narrow depth of field

DSLR Lenses



- Prime - fixed focal length, many sizes
- Telephoto - variable focal length with zoom usually $> 60\text{mm}$
- Super Telephoto - $>300\text{mm}$
- Doublers - add to base of lens (2x)



DSLR Lenses

- Tilt-Shift - for doing perspective corrections
- Extenders & Mount Adaptors (eg Nikon to Canon)
- Filters - WIDE variety from selecting wavelengths to reducing light, polarizing light, star refractions, etc.
- Flashes